

Shanghai Tunnel Engineering Co. Ltd



Tunnel construction site in Shanghai with sludge sediment reservoirs and pumping station

Task

Shanghai TEC is one of the largest tunnel construction companies in China and has already built several road tunnels under the Hangpu river. In the past the sediment from the sedimentation tanks had always been taken to the landfill site or harbour by truck.

However, this traditional way of working requires a large number of personnel.

Putzmeister was able to convince TEC that pumping the sediment from the sedimentation tank at the tunnel construction site to the harbour basin 700 m away would be a



more economical and environmentally-friendly solution.

Material transport

The sediment is pumped continuously from the sedimentation tank through the industrial area directly to the loading point at the harbour via a DN 200 pipeline using two pumps at a maximum rate of 50 m³/h each.

Material

The material to be pumped is the excavated material from the tunnelling machine, which is conveyed to a sedimentation tank to be separated from its very high water content. The material is very fine and sandy and has a solids content of approximately 40 % and a pressure loss of approximately 0.08 bar/m.



Two S-tube pumps with integral Secatol inlet and mixing hoppers with a volumetric capacity of approx. 7m³



A digger fills the supply screw conveyors with sedimented sludge

◀ A screw conveyor supplies each inlet hopper with sludge



BLI concentric nozzle with water connection for reducing pressure losses



Hydraulic power pack HA 132 E

Plant equipment

Two identical pump lines with the following equipment were supplied to this tunnel construction site:

- KOS 1470 HP
- SECATOL intake hopper with agitator
- HA 132 E hydraulic power pack
- BLI ring nozzle with a high-pressure water pump
- Control cabinet with Siemens PLC and integrated operators panel

Output

Each of the two pumps can work at a maximum rate of 50 m³/h, depending on the tunnelling power of the tunnelling machine. The pumps normally run for 20 – 24 hours a day.

Delivery pressure

The delivery pressure required for the 700 m from the pump to the harbour can be set to approximately 50 bar if a BLI system with water is used.

Pipeline length / diameter

The pipeline has a nominal diameter of 200 mm and runs horizontally for 700 m with a difference of level of approximately 10 m.

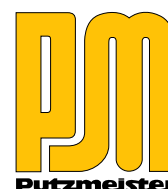
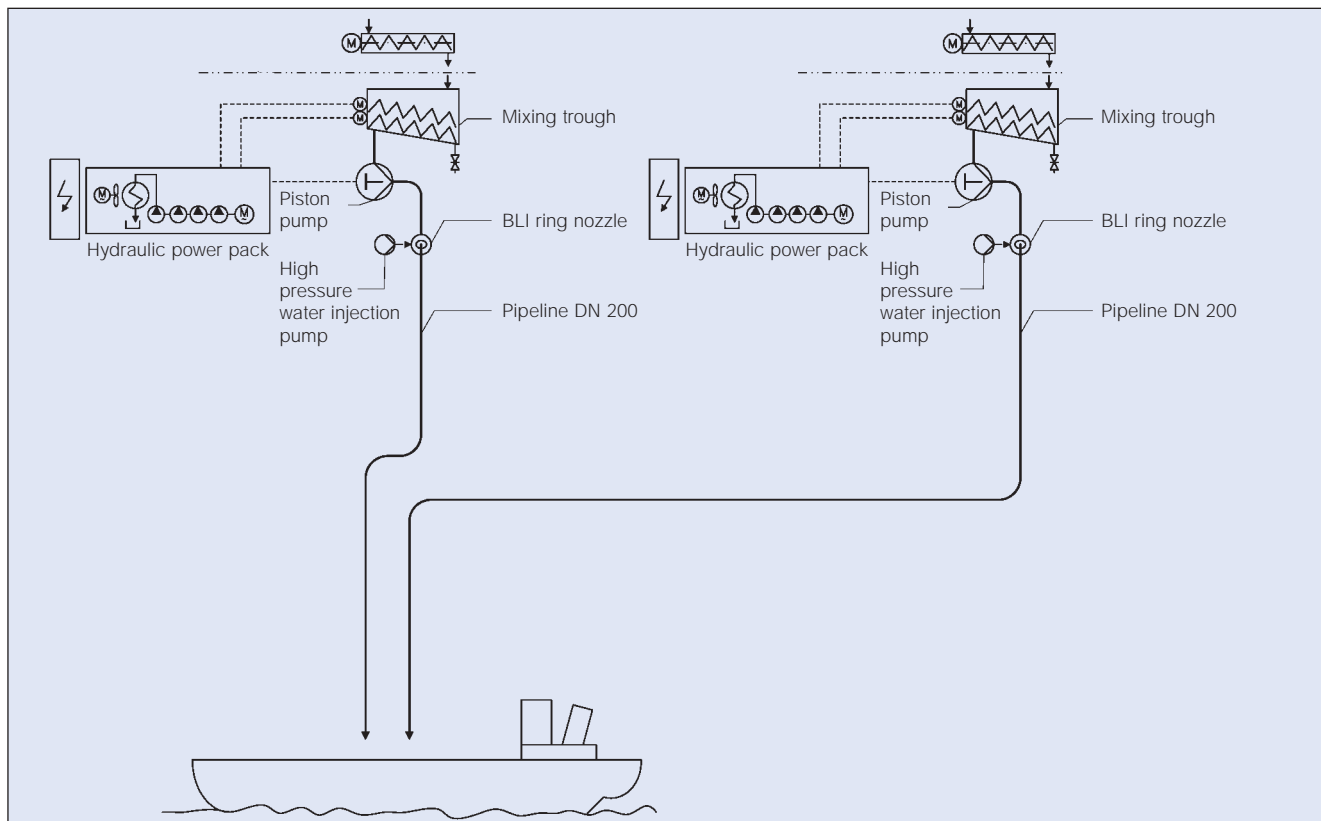

Putzmeister AG
 Max-Eyth-Str. 10 · D-72631 Aichtal
 P.O.Box 21 52 · D-72629 Aichtal
 Tel. +49 (71 27) 599-0
 Fax +49 (71 27) 599-988
 Internet: <http://www.putzmeister.de>
 E-mail: PAT@pmw.de